



# WORKALL<sup>®</sup> Model JDX

### STANDARD FEATURES

90 HP DIESEL John Deere  
 4 WD HYDROSTATIC  
 ARTICULATED STEERING 45 deg.  
 CENTER OSCILATION 30 deg.  
 INSTRUMENTATION PANEL  
 PTO (70 HP) FRONT & REAR (540 rpm)  
 CAT II & I 3-PT HITCH FRONT & REAR  
 FULL BELLY PANS

R.O.P.S./F.O.P. ENCLOSED CAB  
 DRAW BAR - FRONT & REAR  
 IND. FRONT LIFT ARMS CONTROLS  
 TWO REMOTE HYD CONTROLS  
 14.9 X 24 AGRICULTURAL TREAD  
 FUEL TANK 40 USG  
 WT. 9500 lb.

### OPTIONAL ACCESSORIES

HEATER/AIR CONDITIONER  
 HEAVY DUTY RIMS/WHEELS  
 REMOVABLE GLASS WINDOWS  
 REMOVABLE LEXAN WINDOWS  
 WIRE WINDOW PROTECTION  
 FRONT BUCKET LOADER  
 LOGGING GRAPPLE  
 STEEL BELTED TIRES  
 EXTRA WIDE RIMS & TIRES  
 STUDDED CHAINS  
 3 POINT HITCH TO SKID STEER  
 QUICK ATTACH MOUNTING PLATE

MODIFICATION FOR UNIQUE APPLICATIONS IS POSSIBLE

Nelson Tractor LTD. reserves the right to make changes without notice or obligation in materials, components, and size at any time.

## "Attachments - you choose location"

### FRONT OF TRACTOR

Backfill auger	Mower Hammerknife
Backhoe	Post hole digger
Boom for lifting	Shear-trees
Cable logging tower	Sickie knife mower
Chipper-brush	Snow blower
Cultivator	Sprayer
Fire fighting Pump	Sweeper-power
Fire ripper blade	Stump grinder
Fork lift	Tree spade
Generator	Water pump
Grader blade	Winch
Grapple-logs	York rake
Loader	
Mixer-concrete	
Mower-finish	

### REAR OF TRACTOR

Backhoe	People transport
Boom for lifting	Post hole digger
Cable logging tower	Plow-disc or moldboard
Chipper-brush	Rototiller
Cultivator	Sander-salt
Ditcher	Scarifier
Fire fighting equipment	Sickle knife mower
Fork lift	Sprayer
Generator	Spreader-lime or seed
Grader blade	Sweeper-power
Grapple-logs	Stump grinder
Harrow-disc	Trailer
Loader	Water pump
Mixer-concrete	Water tank
Mower-brush hog type	Winch
Mower- Finish	York rake
Mower- Hammerknife	

Attachment Applications (Attachments Sold Separately)

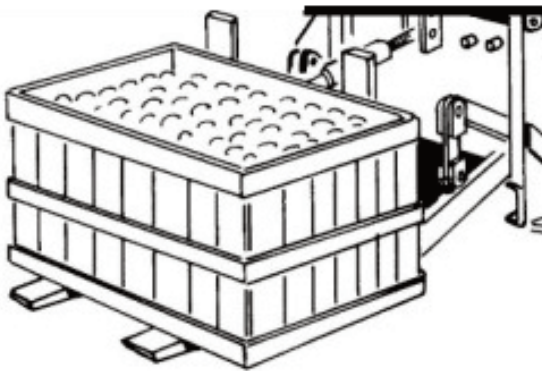

Fork Lift

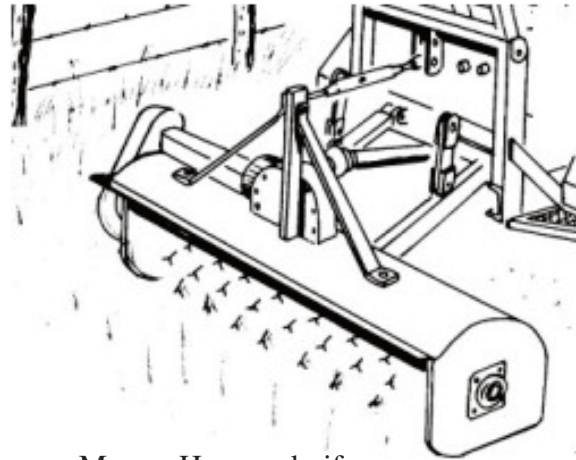

Mower Hammerknife



Grapple-logs

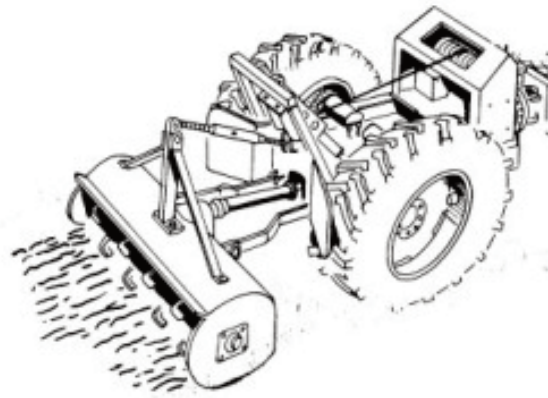

Rototiller

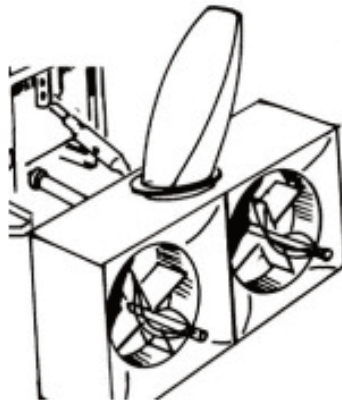

Snow Blower

**COLLINS WORKALL®**

**Nelson Tractor LTD. Maury Collins**

521 Old Stoddard Road, Nelson, NH 03457 Tel. 603-847-3321 Email: [collinsworkall@yahoo.com](mailto:collinsworkall@yahoo.com)

